

# 2008



# PILOT TRAINING MANUAL

## CHAPTERS

<b>QUICK REFERENCE PREFLIGHT CHECKLIST</b>	<b>1</b>
<b>Chapter I: INTRODUCTION</b>	<b>4</b>
Goals of the Training Program	
Components of the Training Program	
Acknowledgements	
<b>Chapter II: TERMINOLOGY</b>	<b>5</b>
Aircraft Terminology	
Flight Terminology	
<b>Chapter III: BASIC STABILITY AND CONTROL</b>	<b>10</b>
Center of Gravity and Airplane Weight	
Six Degrees of Freedom Controls	
<b>Chapter IV: RADIO CONTROLS</b>	<b>13</b>
<b>Chapter V: SAFETY AND OPERATING RULES</b>	<b>15</b>
Safety Rules	
Operating Rules	
Transmitter Impound and Frequency Control Procedures	

<b>Chapter VI: ENGINE MECHANICS</b>	<b>17</b>
Engine Size and Type	
Propellers	
Breaking In the Engine	
Maintenance	
Fuel	
<b>Chapter VII: PREFLIGHT CHECKLISTS</b>	<b>22</b>
First Flight (New Model)	
First Flight (Each Day)	
Each Flight	
<b>Chapter VIII: BASIC FLIGHT MANEUVERS</b>	<b>23</b>
<b>Chapter IX: TRAINING PROGRAM</b>	<b>IX</b>
<b>Chapter X: SOLO FLIGHT</b>	<b>X</b>
<b>Chapter XI: STUDENT FLIGHT LOG</b>	<b>XII</b>

## QUICK REFERENCE PREFLIGHT CHECKLIST

### General Safety Tips

- Never fly alone.
- Keep hands and face out of propeller arc.
- DO NOT LEAN OVER A RUNNING ENGINE TO ADJUST ANYTHING.
- Never fly over houses, near or over people or power lines.
- Rubber bands can lose their hold in very cold weather.
- Be careful with loose clothing around a running engine.
- Sand the edges of a new nylon propeller to remove the sharp edge.

### Aircraft

- Airframe: Check for warps, cracks, loose joints, etc.
- Control Linkages: Verify all linkages are secure.
- Control Surface Throws: Verify throws are correct for model.
- Alignment: Verify all flying surfaces are at the proper angle relative to each other.
- Hinges: Check condition. Replace if necessary.
- Balance: Verify the center of gravity (cg) is within the range shown in the manual. Verify the lateral or side-to-side balance.
- Is the covering tight with no visible signs of damage?
- Are all retaining bolts in place and secure?
- Are any hatches, cowls and canopies secure?
- Are all components structurally sound?
- Are your name and contact information marked on the model somewhere easily visible in case it's lost?

- 

### **Radio Control System**

- Servos: Verify all servos are securely mounted to the aircraft.
- Servo Horns: Properly screwed to servos. Loctite is recommended on metal geared servos.
- Servo Direction: Verify each servo moves in the proper direction with the corresponding transmitter inputs
- Receiver: Ensure it is mounted securely but protected by foam. Check antenna to ensure it's properly routed and secure.
- On/Off Switch: Ensure it is functioning properly. Old switches can have worn contacts that lead to power interruption.
- Battery: Verify its charge level and capacity before each flight both transmitter and receiver.

### **Range Check:**

- Ensure that radio batteries have been properly charged.
- If frequency pin is available, range check the plane with antenna collapsed.
- Check to ensure that all flight controls and the throttle move smoothly and in the proper direction.

### **Engine & Propeller**

- Firewall: dry, fuel-proofed and solid.
- Mounting Screws: Verify they are tight.
- Muffler: Verify muffler attachment to be secure.
- Glow Plug: Replace if old or excessive carbon buildup exists.
- Propeller: Check for nicks or cracks - replace if any found. Check propeller balance before mounting on engine.
- Propeller Nut: Verify tightness.
- Spinner: Check condition and tightness.

### **Landing Gear**

- General: Check general condition of landing gear
- Wheels: Inspect and verify they spin freely. Check tightness of wheel collars
- Centering: ensure the plane rolls straight when the rudder stick is neutral.

### **FUEL:**

- Fuel Tank: Check for leaks and check front screw for tightness. Verify fuel tank is secure in aircraft and that the clunk moves freely.
- Fuel Lines: Check for leaks and/or blockage. Replace if necessary.
- Fuel Filter: Check for stoppage. Clean or replace if necessary.

## **Starting the Engine**

- If using a glow engine, be sure kill switch is enabled to keep engine from starting accidentally.
- Put AMA card in proper frequency slot of flight board and be sure frequency flag is placed on antenna of your transmitter.
- Place plane and flight box on flight line, and switch on the transmitter with antenna collapsed and then switch on the flight pack.
- Operate sticks in all directions and make sure control surfaces are functioning properly in correct directions, and throttle and any retracts are working properly.
- Watch for glitches that might indicate frequency interference or radio problems.
- If using a glow engine, be sure kill switch is enabled to keep engine from starting accidentally. Prime (if necessary) engine through carburetor and make sure needle valve is adjusted per manufacturer's instructions.
- Make sure throttle is set to low speed (slightly above idle)!
- Connect glow plug connector/battery making sure it is clear of prop. If using a control panel, set heat control to proper setting. If using gas engine, disable kill switch to allow engine to start.
- Tether plane or have an assistant hold fuselage from behind tail.
- Flip the prop or use engine starter to turn it while keeping clear of prop!
- Once engine starts, move behind prop and keep fingers clear of prop while removing glow plug connector/battery of non-gas engine.
- With plane still being held, rev up engine and if necessary, adjust needle valve.
- Set throttle to idle and if necessary, adjust low speed setting.
- Rev up engine slowly to full speed while working control surfaces to make sure they function properly.
- Throttle back and make final carburetor adjustments if necessary (engine still running rich or lean).
- Once the carburetor is properly adjusted, it is a good idea for your assistant to hold the plane in a high attack mode while you are revving the engine up to about half speed and back to idle to make sure fuel feed is constant. Full speed is not recommended for .45 and larger size engines during high attack mode testing.



## **Chapter 1: INTRODUCTION**

Welcome to the exciting, challenging and wonderful world of radio controlled aeromodeling. Golden Triangle R/C Club is dedicated to producing pilots who are proficient, safe and skilled. This manual contains the basic materials that will be used in your pilot training. This flight training program is designed to give you sufficient skills so you can pilot an RC model through take-off, basic maneuvers and landing. The normal procedure is for you to select an instructor to take you through this course. When your instructor feels you are ready to solo, a different instructor will supervise your solo check flight.

### **Goals of the Training Program:**

The goals of this pilot training program are:

1. To promote safety, both in the air and on the flying field.
2. To develop competent radio controlled model aircraft pilots.
3. To create a program that efficiently turns beginners into solo-certified RC pilots.
4. To provide consistency and uniformity in the training program.
5. To document the student's progress to ensure that these goals are met.

### **Components of the Training Program:**

This training program is fairly comprehensive for a student RC pilot. It is designed to cover the areas of aircraft terminology, aerodynamics, stability and control, how a radio controls your model, safety and operational procedures, engine mechanics, and preflight procedures. These issues are preparatory for the actual flight training. The flight training is designed to follow an orderly progression of lessons culminating in solo certification.

This manual is divided into eleven chapters and pages of each chapter are numbered independently to facilitate changes and additions.

## **Acknowledgement:**

Golden Triangle R/C Club is fortunate to have a number very qualified and skilled instructors to assist student pilots in becoming proficient in the flying of radio controlled model aircraft. A number of the instructors have made a valuable and insightful contribution to the contents and philosophy of this flight instruction program. Without their help, suggestions and encouragement this official training program would not be possible.

## **Chapter II: TERMINOLOGY**

In order to facilitate this training process it will be helpful to first be clear on terminology. Aircraft terminology has evolved over the past 100 years with terms and words that are not found in common everyday language. Because the flight of aircraft, including model aircraft, is a very complex physical phenomenon, your understanding of the lessons that follow will be greatly helped if you understand the commonly used terms. The terminology learned in this chapter will facilitate your understanding of your model and communication with your instructor.

### **AIRCRAFT TERMINOLOGY**

**Types of aircraft:** The wing is the most important part of the aircraft. The number of wings, the motion, and the shape of the wing also leads to terminology that distinguishes the type of aircraft.

**One Wing:** A bird has a pair of wings. An airplane has a pair of wing “panels,” meaning left and right sides. An airplane with one wing is called a monoplane. a term seldom used today (since most aircraft today are monoplanes).

**Flying Wing:** A pure flying wing does not have a fuselage or horizontal tail. With advancements in computerized stability and control augmentation systems, flying wings have become more appealing. A good example is the Northrop B-2 Stealth bomber.

**Multiple Wings:** Aircraft have been designed with multiple wings, particularly in the early days of aviation. An airplane with two wings is called a biplane and an airplane with three wings is called a triplane. The most common arrangement is to locate the wings above each other. When the top wing is placed slightly forward of the bottom wing(s) the aircraft is said to have positive stagger. If the top wing is placed slightly behind the bottom wing, the aircraft is said to have negative stagger.

**Tandem Wings:** A tandem wing airplane has two wings, one behind the other. The difference between a tandem wing airplane and a biplane is that the stagger between the two wings is very large and generally there is no horizontal tail. The term tandem wing also infers that the wings are of approximately the same size. The tandem wing design dates back to the Wright brothers. These arrangements are not efficient

and are difficult to control. If the forward wing is smaller than the aft wing by more than 50 percent, the forward wing is called a canard.

**Canard:** A canard surface is a small wing surface located forward of the main wing. The purpose of this surface is to control the pitching movement of the airplane. Designs with this arrangement are currently having more success than in the past.

**Helicopter:** The helicopter is a rotating wing driven by an engine. The rotating surfaces are called rotor blades and are similar to propeller blades. Control of the pitch angle of the rotor blade controls the amount of lift. The cyclic change in the pitch angle causes the cone of rotation to tilt, producing forward, rearward, and sideward motion.

**Gliders:** Gliders are un-powered airplanes. They glide to the earth's surface from aloft using the wing's lift to reduce the rate of descent. A sailplane is a high performance glider designed to stay aloft by riding upward air currents, called thermals.

## **WING GEOMETRY**

**Leading and Trailing Edges:** The leading edge of the wing is the line connecting the most forward points of the wing. The trailing edge is the line connecting the most rearward points of the wing.

**Wing Tip:** The wing tip is the shape defined by a line connecting the leading and trailing edges. The wing tips are the most outward edges of the wing. The leading edge, trailing edge, and wing tip outline the plane of the wing.

**Span,  $b$ :** The span is the length measured by a straight line from the outermost point on one wing tip to the outer most point on the other wing tip. The definition of span is the same for all wing shapes. Note that dihedral (defined below) reduces the length of the span when compared to a flat wing without dihedral.

**Chord Line and Chord;  $c$ :** The chord line is a straight line from the leading edge to the trailing edge, parallel to the center line of the wing. The chord is the length of the chord line. The chord line and the chord of the wing are the same as the chord line and chord of the airfoil.

**Dihedral Angle,  $\gamma$ :** If the wing is placed on a flat surface so that each wing tip is at equal distance from the surface, the dihedral angle is the angle between the plane of the wing and the surface. The wing panels are joined in a "V" shape. The dihedral angle is the same for both wing panels.

**Area,  $S$ :** The wing area is the projection of the area of the wing on a flat surface, including the area enclosed by the fuselage. Note that the effect of the dihedral angle is to reduce the wing area.

**Aspect Ratio, AR:** The purpose of the wing is to generate lift. The amount of lift depends on the amount of air the wing can capture. For a given wing area at a given speed, a longer span wing will capture more air in a shorter distance than the smaller span wing. The aspect ratio relates the span to the area. The aspect ratio is equal to the span (b) squared:  $b \times b$ , divided by the area, S. For a rectangular wing the aspect ratio is simply the span divided by the chord. Gliders have very high aspect ratios which allow them to generate lift at a much lower speed. As the aspect ratio is reduced the airplane will have to fly faster to generate enough lift to keep airborne.

**Washout:** There are two types of washout. Geometric washout is where the chord lines at the tips twist downward, referenced to the chord line at the center of the wing. Aerodynamic washout can be designed into the wing by making the airfoil section at the tip different than at the center of the wing. The effective angle of attack at the tip is less than at the center. Washout can be very useful on models to make the tip stall after the center section of the wing stalls (or, the wingtips will remain more stable at slower speeds than the center of the wing). This will improve control at low speeds.

**Airfoil:** The airfoil is the cross-sectional shape of the wing obtained by passing a plane through the wing parallel to the wing's centerline and perpendicular to the plane of the wing. Early airfoil shapes were almost entirely guess work. Research during WW I produced more efficient sections, such as the Clark Y and Gottingen sections. Later, studies by the National Advisory Committee for Aeronautics (NACA) separated the effects of the airfoil camber from the distribution of thickness. This breakthrough in the middle 1930's led to current methods for airfoil design.

**Flaps:** Flaps are hinged surfaces, normally on the inboard trailing edge of each wing panel that deflect downward to change the shape of the airfoil camber line. The effect is to increase the lift of the wing; they are often used on heavy models for take-off and landing.

**Ailerons:** Ailerons are hinged flaps on the outer portion of the wing panel that provide roll control. In models, strip ailerons normally span the entire wing panel. Ailerons move in opposite directions to produce unbalances in the lift, creating a rolling moment around the longitudinal axis of the airplane.

## **FUSELAGE**

**Fuselage:** The fuselage is the central structure that supports all the parts of an airplane, such as the wing and tail. The fuselage is also that part of a model that accommodates the engine, fuel tank, radio and most of the control servos.



**Reference Line:** All fuselage design measurements are made from the reference line. The location of this reference line is arbitrary. Normally the reference line is level with the surface of the earth in level flight (somewhat like the water line on a ship).

**Incidence Angle:** The incidence angle is the angle between the chord line of the wing or the horizontal tail and the fuselage reference line. The leading edge of the wing or horizontal tail is above the reference line for a positive incidence angle.

## **TAIL SURFACES**

**Empennage:** The term empennage can be used to describe the combination of all the tail surfaces of an airplane.

**Horizontal Tail:** The horizontal tail has two surfaces, the stabilizer and the elevator. The stabilizer provides stability, the elevator is a flap surface hinged to the stabilizer. The elevator moves both up and down to control the angle of attack of the airplane. The elevator also provides part of the stability.

**Vertical Tail:** Like the horizontal tail the vertical tail has two surfaces, the fin and the rudder. The fin is the stationary forward part of the vertical surface. It provides directional stability. The rudder is the moveable surface hinged to the rear of the fin and provides directional control.

## **FLIGHT TERMINOLOGY**

The following terms are associated with the environment of the flying model and the orientation of the model during flight.

**Altitude:** Altitude is the distance of the model above the surface of the earth and measured in feet.

**Heading:** Heading is the direction the model is flying and is measured from north in degrees. Flying due east is a heading of 90 degrees.

**Airspeed:** Airspeed is the speed of the model through the air and normally is measured in miles per hour. Note that this is the speed of the model through the air mass and is different than the ground speed if there is wind present. When a model is flying at a given airspeed in the direction of the wind it will be moving faster with respect to the stationary RC pilot on the ground. Conversely, when the model is flying at a given airspeed into the wind it will be moving slower with respect to the stationary RC pilot on the ground. It is important to take off and land into the wind to reduce the ground speed while increasing the airspeed which makes these maneuvers easier.

Attitude:	Since a model can rotate about all three axes it can experience a pitch, yaw and roll angles which change the fuselage reference line with respect to the direction flight. These angles combine to define the attitude of the model. The angle between the wind direction and the chord line of the wing is called the angle of attack. The angle between the plane of symmetry and the wind is called the angle or side slip. The angle between the plane of the wing and the horizon is called the bank angle (or roll angle).
Runway:	The runway is that portion of the hard surface used for takeoff and landing.
Taxi Way:	The taxi way is that portion of the hard surface on the extreme edge of the runway used for taxiing to the takeoff position or used for returning to the startup box.
Pilot Station:	Pilot stations are the pad areas along the taxi way, protected by the net barriers, used by pilots and their helper while the model is being flown.
Startup Box:	Startup boxes, the areas immediately behind the pilot stations, are used for starting engines and preparing for takeoff. These areas are also referred to as hot boxes. The models must be pointed away from spectators and other pilots. Only the pilot and helper(s) are allowed in the startup box.
Ready Box:	The ready box is the area directly behind the startup box where the next model to fly at that pilot station can be placed.
Traffic Pattern:	The traffic pattern is the flow of the air traffic prescribed for landing and taking off. The usual components are the upwind, crosswind, downwind and base legs, ending with the final approach. The traffic pattern can either be left or right with respect to the pilot stations, depending upon the wind direction.

### Chapter III: BASIC STABILITY AND CONTROL

**Center of Gravity and Airplane Weight:** Model airplanes experience the attraction of gravitational forces that pull it toward the earth's surface. The airplane can be considered as a large number of connected weights, each part experiencing the pull of gravity. The entire model is a set of small downward forces. The center of gravity is the centroid of all these forces. The location of the center of gravity is very important for proper stability and control. Manufacturers of models normally show the proper center of gravity (c.g.) either on the plans or in the instruction booklet that comes with the kit. Although a model can be stable over a small range of c.g. locations, it is vital that the proper c.g. be obtained prior to the first flight of a new model. The c.g. can be changed by moving the radio equipment and/or by adding weight, either in the nose or tail. It is desirable to make the c.g. adjustments with the on board equipment, rather than adding dead weight. But in some models this is not always possible.

**Six Degrees of Freedom:** To discuss stability and control of an airplane it is convenient to represent the airplane by a set of three mutually perpendicular axes. The system is made by the intersections of three planes: 1) the plane of symmetry (pitch), 2) the plane of the wing (yaw), and 3) the roll plane. The origin of the three axes is the center of gravity. The diagram below illustrates these three planes.

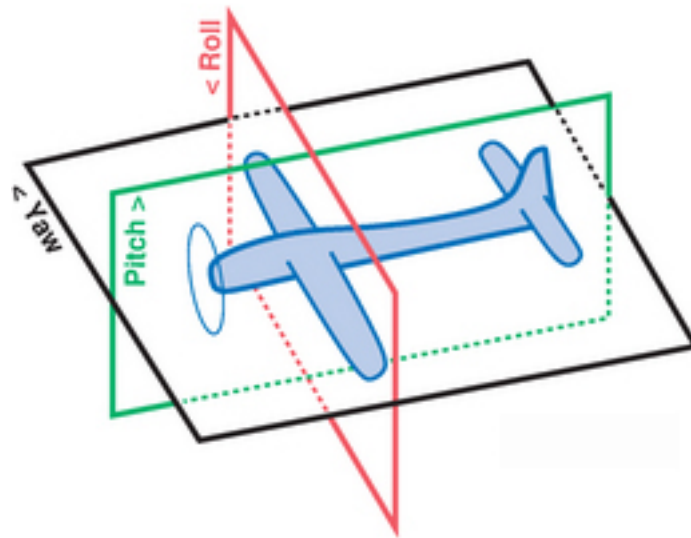

A model moves in six degrees of freedom. It can move along all three axes and it can roll about all three axes, giving it six ways to move. This is a very complex set of motions that have coupling forces that interact between axes. For example, a roll about the longitudinal axis can also produce yaw about the vertical axis.

**Controls:** The primary control surfaces are the elevator, rudder and ailerons. These surfaces control changes in airspeed, direction, attitude, and altitude of the model. The diagram below shows how the control surfaces affect changes about the three axes described above.

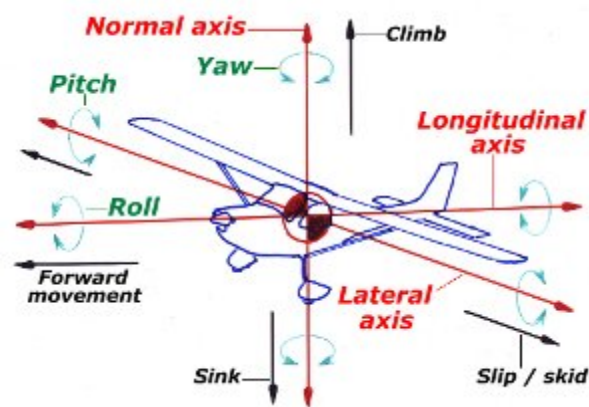

**Elevator:** The elevator causes a moment about the center of gravity, which in turn changes the model's angle of attack to the wind. Deflecting the elevator's trailing edge up creates a force downward at the tail causing the nose to rise or pitch up. A down elevator deflection causes the opposite to occur, namely a pitch down.

**Rudder:** The rudder provides directional control. Direction refers to the position of the model with respect to the wind in the planform view. The primary function of directional control is to correct for sideslip during straight and turning flight. The rudder produces a force in the same manner as the elevator, only the moment is about the vertical axis and is referred to as a yaw moment. The angle between the reference line of the fuselage and the wind is called the sideslip angle.

Several flight conditions can introduce yawing moments and sideslip that can be corrected by deflecting the rudder. When the model is rolling into a turn, the roll control creates a yawing moment. The rudder is used to cancel this moment. The slipstream created by the propeller has a rotational component that changes the angle of attack of the vertical tail surface. This change in angle can cause a yawing moment and is corrected by a rudder deflection. The rudder is also used to produce a sideslip required to follow a straight path, referenced to the ground, during cross wind landings and take-offs. The rudder is also the primary recovery control in spin recovery.

**Ailerons:** Ailerons provide lateral control. The ailerons deflect asymmetrically, one up and one down. The aileron that deflects downward creates additional lift on its side of the wing. The aileron that deflects up reduces the lift on its side of the wing. This asymmetrical lift distribution causes the model to roll about the longitudinal axis. The resulting motion is unlike that produced by the elevator or rudder. When the elevator or rudder are deflected, other surfaces produce moments that oppose and cancel the motion. However, when the ailerons are deflected, only the wing creates an opposing moment. This moment is a damping moment that only limits the rate of roll, but which is never large enough to prevent the ailerons from making the model roll.

To stop the rolling motion of the wing, the ailerons must be deflected in the opposite direction and then returned to the neutral position. When the rolling motion stops, the model will be trimmed at a roll angle. Maintaining the roll angle results in a bank and the model will turn in direction or heading. Normally the turn will continue until the wing is returned to a level position using the ailerons. The very stable nature of training models with large dihedral angle, usually means the model will tend to roll back to level the wings.

It is important to learn to use other controls in conjunction with the ailerons. For level flight all forces are in balance. But when the model banks in a turn it creates an imbalance between the weight and lift. Since the vertical component of the lift must equal the weight it will require deflecting the elevator to increase the angle of attack, hence increase the lift to equal the weight. The sharper the turn the more up elevator is required to maintain a constant altitude. Since deflecting the elevator also increases the drag it might be necessary to add power to maintain the airspeed of the model. A coordinated turn requires the use of all controls: the ailerons, the rudder, the elevator, and the throttle.

Steady turning flight imposes high stresses on the airplane's structure. The greater the bank angle the larger the lift force generated. When the bank angle is 60 degrees the lift force is twice the weight of the airplane, resulting in a "2g" turn. At 70 degrees the lift force is almost three times the weight, or 3g's. It is not uncommon to see the wings on models break because of high G turns or pullouts from dives.

## **Chapter IV: RADIO CONTROLS**

Modern radio control systems are very reliable and permit the control of model aircraft in very precise ways. For the purpose of this manual a basic four channel radio system will be explained, since this is the normal set-up for a trainer aircraft. Most radios today come with two gimballed sticks that enable the pilot to mix all four functions simultaneously. They are also referred to as proportional control systems because the control surface on the model responds proportionally to deflections of the sticks on the transmitter. Radios are sold in both Mode I and Mode II configurations. The difference between modes has to do with where the elevator and throttle are located. In the Mode I configuration the elevator is on the left stick and the throttle is on the right stick. In Mode II configuration the throttle is on the left stick and the elevator is on the right stick.

A four channel radio system comes with a transmitter (TX), a receiver (RX), four electric servos, batteries for both the transmitter and flight pack (receiver and servos), a switch harness and a charger. The batteries are usually nickel cadmium (Ni-Cd) and if properly maintained will last several years. Be sure the batteries are always fully charged before every flying session.

It is important to understand what function on the transmitter controls which surface on the model. For the purpose of this manual only Model II transmitters will be described. The right stick should have the ailerons on the right to left motion and the elevator on the up and down motion. It is helpful to think of this stick in the same way as full-sized aircraft sticks. When you pull the stick back (down) it deflects the elevator into the up position increasing the lift causing the nose of model to rotate in an upward direction. The ailerons are deflected by a left to right movement of the right transmitter stick. Remember that moving the stick to the left should cause the left aileron to deflect up and the right aileron to deflect down, causing the model to roll to the left. Most modern transmitters have reversing switches built into them, either on the front or under the panel in the back. If the control surfaces are going in the wrong direction relative to the movement of the transmitter sticks change the reversing switch on the appropriate channel.

The left stick controls the rudder with a right to left movement and the throttle with an up and down movement. The rudder control is also connected to the nose or tail wheel and used for steering during taxiing and take-off. Note that the rudder, aileron and elevator control sticks will return to neutral when the sticks are released. The throttle will stay where it is placed.

Each gimbal function also has a trim adjustment lever. On the right stick the elevator trim is the small lever immediately to the left of the gimbal. The trim levers move in the same way as the stick function. The elevator trim lever moves up and down, and the aileron trim lever (which is immediately below the right gimbal) moves left and right. The throttle and rudder also have similar trims on the left gimbal. These trim levers are used

to make minor adjustments to the controls surfaces necessary in “trimming” the aircraft to fly straight and level with both sticks in their neutral position.

On the maiden (first) flight of a new airplane there is usually some trim adjustment necessary, either because the model hasn't been built perfectly true, or because the control surface rigging is off a little bit, or because the center of gravity is not exactly the same as on the original prototype model. After the maiden flight the control linkages should be adjusted to compensate for the trim offsets encountered during the trim flight. The object is to get the model to fly straight and level with all the surface control trims at zero. This might take several flights of adjusting the lengths of the pushrods. When this is accomplished you will always know where the trims should be when you do your pre-flight checks. These trim levers have a way of being moved when the transmitter is being handled, so going to this trouble will save having to re-trim the airplane every time it is flown.

The receiver and flight battery should be wrapped in foam to protect them from vibration or damage during a crash or hard landing. The manufacturers of all trainer kits or ARFs have specific instructions on the radio and servo installation. Be sure that all pushrods and control connects are free of binding or sticking. If the servos have to work hard to move the control surfaces they will draw more electrical current and may endanger your airplane.

All radio systems with sold a charger that charges both the transmitter and flight battery pack. This charger is rated to fully charge your system from a discharge situation to a fully charged system in 16 hours. Therefore, you should always charge your system overnight before going flying.

---

**Note:** Many pilots would state that battery lifetime can be extended through discharge cycling. Some contend that a battery cycler is a good investment because it will cycle the batteries down to a certain level and then automatically recharge the batteries. After 16 hours it will automatically put the batteries on a trickle charging cycle. At the trickle charge rate they can be left on the charger indefinitely until you are ready to fly. The other feature of a battery cycler is it will tell you how much time you can safely fly the system from a fully charged level.

## **Chapter V: SAFETY AND OPERATING RULES**

It is mandatory that all pilots being trained by GTRCC obtain proper insurance through the Academy of Model Aeronautics. This provides the necessary liability insurance and protection for both pilots and spectators. It is important for all student pilots to be familiar with the current Safety Code of the Academy. This will not be repeated here, but is the general safety code for all activity at the flying site and all pilots are expected to know and follow this code.

In addition, GTRCC may have additional safety and operating rules that need to be observed by all pilots. These rules are presented in this Chapter and are also posted at the flying site.

### **Safety rules for club members:**

1. The Academy of Model Aeronautics National Model Safety Code will be observed at all times.
2. All pilots will follow the Frequency Control Procedures without exception. Transmitter impound may be required at club sanctioned events.
3. The Safety Officer has the last word. All requests from the Safety Officer will be observed. The Safety Officer may ground any airplane or pilot which presents a potential safety hazard. Any disputes over Safety Officer decisions or these Club Rules will be resolved at the next scheduled meeting of the Board of Directors following the dispute.
4. No combustion engine will be started outside the designated engine break-in areas. A second person or restraining device should be used when starting engines.
5. There will be only one piloted flying aircraft per flying station.
6. No person shall approach the runway without loudly announcing their intentions. Always check for landing aircraft before taxiing onto the runway.
7. High speed and low speed passes, and all aerobatic flight will be performed to the far side of the runway centerline.
8. Non-Club members acting in an unsafe manner will politely be asked to correct their actions. Continued unsafe acts will be reported to the field safety officer.

### **Operating Rules:**

1. Alcoholic beverages will not be consumed by a pilot before or during flying.
2. There will be no flying west of the runway.
3. All take-offs and landings will be made into the direction of the prevailing wind. Emergencies or dead stick landings may be made in either direction after the pilot loudly announces his/her intentions. Any member changing the direction of the active runway is responsible for notifying all pilots occupying pilot stations.
4. Pilots making touch and go or full stop landings must loudly announce their intentions. Landing aircraft have priority over aircraft taking off. Emergency and dead stick landings have priority over powered landings.
5. Maintenance tables are only to be used for assembling, disassembling, inspection and performing maintenance on models. Assembled models which are not in maintenance should be placed in the pit area.
6. During fueling and defueling, fuel "catch cans" or other appropriate device or means will be used as necessary to avoid fuel spillage.

## Chapter VI: ENGINE MECHANICS

### Engine Size and Type:

There is a wide variety of very powerful and efficient model aircraft engines available to the modeler today. They come in all sizes and configurations. For the beginner the most common size and type is a two-cycle (two-stroke) .40 cu. in. single cylinder alcohol burning engine. A two-cycle engine refers to that fact that the engine has two strokes: a compression-ignition and a power-exhaust stroke. The displacement is the measure of the engine's size and power. A .40 cubic inch engine means that during the movement of the piston from the bottom of its travel to the top it displaces a volume of .4 cubic inches. The displacement is a function of the stroke and cylinder bore of the engine. These engines fire every time the piston comes to top dead center (the highest point in the piston's travel).



Four-cycle (four-stroke) engines have valves much like an automotive engine and only fire every other time the piston hits top dead center. Four-cycle engines are heavier than a two-cycle engine of the same displacement. Although these engines are becoming more powerful, a rule of thumb is a four-cycle engine needs to be roughly 1.5 as big in displacement as a two-stroke engine to get comparable power.

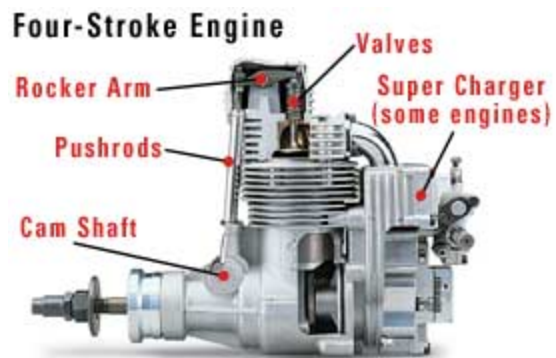



## **Propellers:**

Propeller sizes for novice pilots are not critical. Check the instructions that came with your engine for recommended propeller sizes. Most .40 engines run fine with a 10 X 6 or an 11 X 5 prop. The first number refers to the diameter of the propeller and the second number refers to the pitch of the propeller blade. A rule of thumb is if you increase the diameter an inch you reduce the pitch an inch. Use the recommended flight prop for engine break in.

Props come in a variety of shapes and are made either wood or reinforced fiber. For training purposes a tough reinforced prop is desirable, since they can take more abuse. Landing practice can be hard on props. Wooden props will break or crack with the slightest contact with the ground. Reinforced fiber often will not break. They may get ground off and you need to inspect your props carefully if they do contact the runway to make sure they are still safe to use and to check their balance.

Propellers should be checked for balance. There are excellent prop balancers on the market and every modeler should have at least a finger balancer. Don't be afraid to take your balancer in to the hobby shop and check the props before you buy them. If you find a prop a little out of balance a good way to balance it is to put a thin film of epoxy on the back side of the light blade. You can check it immediately and adjust the amount of glue until it is balanced. After the glue dries it will be smooth and will not change the airfoil of the blade appreciably.

## **Breaking in the Engine:**

If you have never operated a model (glow) engine it is a good idea to break in your engine on the bench. Mount it on a board with a tank and throttle and a throttle arm and then clamp the entire unit to a bench.

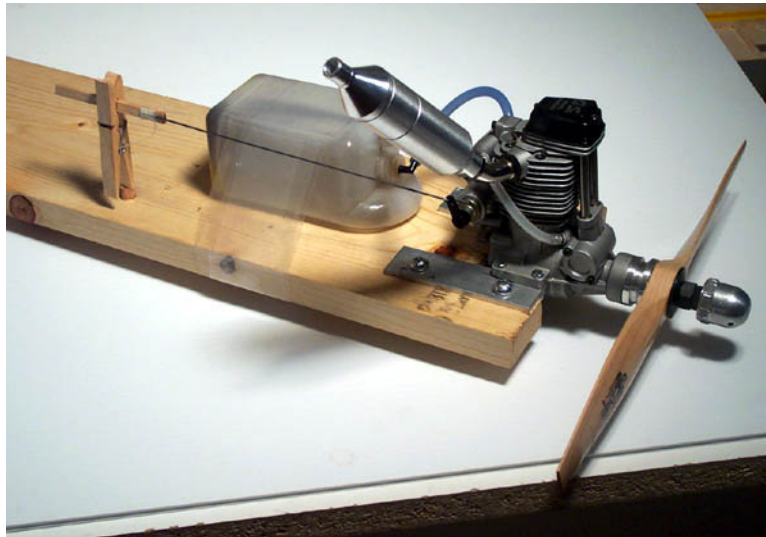

Engine test stands are also available commercially, although they generally are designed for a specific sized engine and can be moderately expensive.

Choose an area away from others to reduce noise; break in engine cycling can become annoying to others trying to talk.

You need to learn how to choke the engine and throttle setting for easier engine starting. Running on the bench will help teach you how to set the idle for the lowest possible rpm (revolutions per minute). Once it is safe to run the engine at full throttle you will be able to determine how long the engine will run on a tank of gas (provided the tank on the stand is the same size as in your model).

How you break in the engine depends on the type of engine. Most modern engines will either have a ring or will be an ABC type. A ring engine has a small ring near the top of the piston. You can check to see if your engine has a ring by looking near the top of the piston through the exhaust port. If your engine doesn't have a ring it is either an ABC or a lapped iron piston. There are not many iron piston engines produced anymore. The ABC stands for aluminum piston, Brass cylinder liner with a Chrome surface. The metallurgy of an ABC engine lets it run looser the hotter it gets. As an ABC engine heats up, the brass cylinder liner expands more than the aluminum piston.

The ringed engine should be broken in with a very rich fuel/air mixture. But an ABC engine should be brought immediately into a slightly rich two cycle fuel air mixture. All engines should be exercised during their break in period. This can be accomplished by running two minutes at high throttle and a minute at idle, then repeating this high and low rpm routine. This process expands and contracts the engine, forcing the piston and cylinder to seat each other.

For a ringed engine it is advisable to run at least two tanks of fuel through the engine before your first flight, but preferably four tanks. Keep the ringed engine running very rich – so it spits smoke and oil from the muffler. It should sputter a bit or sound kind of like a four stroke engine. This very rich running is often called four cycling. Run it just a rich as it will run without the glow starter but still maintaining a constant rpm. If it slow down when you remove the glow starter lean it out until it maintains a constant rpm. If you run four tanks of fuel through the engine during break in, run the first tank very rich as described above. On the second tank, turn the needle valve in a little so the engine runs a little leaner, but still four cycles. On the third tank lean the engine so that it pulses back and forth between four and two cycle operation. On the fourth tank the engine can be run at a rich two cycle setting.

An ABC engine requires a rich two cycle right from the beginning. Start up the engine and turn the needle valve until it smoothes out into a slightly rich two cycle. If you don't do this, it is possible to damage the engine by running it too rich. The engine will not get hot enough and it might put excess load on the connecting rod causing premature wear. It could even make the rod break. Because the ABC engine break in is at a higher rpm than a ringed engine the break in period can be shorter. In fact, an ABC engine can be broken in during flight. Two tanks of fuel through the engine on the test stand should be enough for a beginner to get familiar with the operation of an ABC engine, then it is more than safe to put it in the airplane and continue the break in. But if you are doing most of your break in in the air be sure the engine is running at a rich two cycle. After six or so flights you may be tempted to think that the engine is broken in properly. This is wrong and many RC pilots make a mistake at this point. Keep it on the rich side for months and it will continue to get stronger and more powerful.

## **Maintenance:**

Engine maintenance is very important to keep your engine operating at its peak for years. When you are through flying for the day, take a few minutes to prepare it for storage until your next flying session. Alcohol is the basic ingredient in model fuel and if left in the engine can attract moisture when stored. Therefore, at the end of your flying session pull the line off your carburetor and start the engine and run out any excess fuel still in the engine. Check to make sure all the mounting bolts are tight. Keep the engine clean from excess oil and dirt on the exterior. Using light oil such as 3-in-1 or After Run Oil put a few drops in the carburetor and turn the engine over a few times. Then take a plastic bag or a rag and wrap the engine so dirt and dust cannot collect on the engine while it is in storage.

## **Fuel:**

Model fuel has three main ingredients: Methanol (methyl-alcohol), lubricant (100% synthetic, or a castor oil-synthetic mix), and nitromethane. In the days of iron pistons castor oil was almost used exclusively as a lubricant. As ringed engines came along, the percentage of castor oil decreased. Now with ABC engines with aluminum pistons with a high silicon content the synthetic oils are used almost exclusively. However, synthetic oils do have one big disadvantage. Although the viscosity is the same or slightly higher than castor oil, they do not have as strong a film strength at high temperatures. This means if you run your engine too lean it can damage your engine with excessive wear. This is another reason to make sure you always run your engine slightly on the rich side.

Nitromethane increases the power of the engine by liberating oxygen. You should use a fuel with at least 5% nitro to improve power, make the engine easier to start, and improve the idle. Additional percentages of nitro can further improve the top end performance, but not in great jumps as you might expect. The difference between 5% and 15% is only a matter of five or six hundred rpm.

Methanol is the main ingredient in model fuel. Keep your fuel container lid on tight at all times because of alcohol's nature to attract moisture.

If you have questions about engine operation or if you are having trouble running your engine let your instructor help you.

## TWO-STROKE ENGINE OPERATION

A 2-stroke engine is relatively simple in operation. The crankshaft makes one complete revolution for every power cycle. During the piston's upstroke, the fuel/air mixture above the piston is compressed for combustion. At the same time, a fresh mixture is drawn into the crankcase below the piston. After combustion, the piston is forced downward, and the spent fuel charge is expelled through the exhaust port. At the same time, a fresh fuel/air mixture is drawn through the carb and into the crankcase. The intake valve is sealed, and the mixture is forced through the transfer ports and into the cylinder above the piston to start a new power cycle.

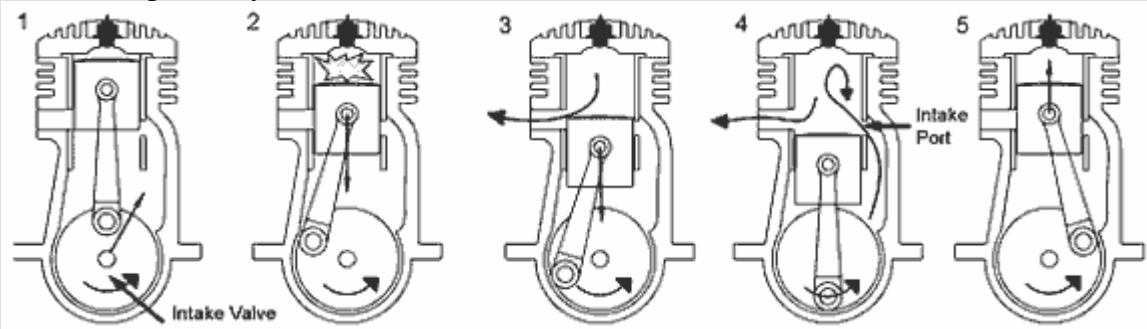

1. As the piston reaches top dead center (TDC), a fresh air/fuel mixture charge is drawn into the crankcase because of the low pressure created as the piston travels upward.

2. The piston then compresses the mixture in the combustion chamber, and it is heated and ignited by the glow plug; this forces the piston down.

3. As the piston comes down, it opens the exhaust port, and the spent fuel begins to exit the combustion chamber. At the same time, the piston compresses the new fuel/air mixture in the crankcase.

4. At bottom dead center (BDC), the piston opens the bypass port, and the new air/fuel mixture charge flows from the crankcase into the combustion chamber as the last of the spent charge leaves.

5. The piston comes back up and seals the exhaust and bypass ports, and the entire process begins again.

## Chapter VII: PRE-FLIGHT CHECKLIST

### First Flight (New model)

1. [ ] Elevator and rudder push rods: There should be no binding, rubbing sticking.
2. [ ] Throttle and steering push rods: Make sure they are operating properly.
3. [ ] Check for proper directions on all control surfaces and throttle.
4. [ ] With radio on, check all control surfaces for zero alignment and proper amount of deflection.
5. [ ] Check to make sure there is no play in control connections at both the servos and control surfaces.
6. [ ] Check to make sure wheel collars, clevises, wing bolts, etc. are all tight. If you are attaching your wing with rubber bands, use at least 12 bands.
7. [ ] With radio on, check: the tracking of your model by pushing it gently on a flat surface. Adjust nose wheel as required to make it track straight.
8. [ ] Test run the engine for reliable idle, smooth transition from idle to full-throttle, and adjust throttle linkage to kill engine at low trim

### First Flight (Each Flying Day)

1. [ ] Check transmitter and flight-pack batteries to make sure they are at full charge.
2. [ ] Range check the radio (check the instructions for your radio to see what the manufacturer recommends for range check). ***Remember, never turn your radio on without following the frequency procedure for your field!***
3. [ ] After starting the engine, adjust needle valve for slightly rich setting. Changes in atmospheric pressure can affect the previous setting. Depending on your field's pit area set up, it may be necessary to kneel in front of the airplane to start the engine. ***However, get in the habit of running up the engine, removing the glow pug starter, and making needle valve adjustments from behind the running engine.***

### Each Flight

1. [ ] Cycle control surfaces while engine is running to check for proper action and no flutter.
2. [ ] Extend transmitter antenna fully.
3. [ ] Check to make sure the trims have not been accidentally changed.
4. [ ] Check wind for proper take-off direction. Always take-off into the wind.
5. [ ] Observe other flying aircraft to determine when it is safe to enter runway. Announce (loudly) your intention to take-off when it is safe to do so. *Since distance and engine noise may prevent others from hearing your announcement to take-off, you are responsible to make sure it is safe to enter the runway area.*

## Chapter VII: BASIC FLIGHT MANEUVERS

The basic flight sequences and maneuvers that are a part of this training are listed below. Your instructor(s) will see that you learn these maneuvers so you will be ready for your solo certification.

	MANEUVER	DESCRIPTION
1	90 degree turns: left and right	Uniform turn rate, constant altitude, roll out and straight and level flight on new heading.
2	Horizontal figure eights: left and right	Establish heading and latitude parallel to runway, perform 90 degree turn away from pit area, followed by a 360 degree turn in the opposite direction, followed by a 270 degree turn in the original direction, followed by a 90 degree turn onto the original altitude and heading.
3	Slow fly by	Establish safe altitude and fly parallel to the runway at minimum controllable airspeed (MCA), maintaining constant altitude.
4	Slow 360 degree turn	Flying at the MCA, perform a 360 degree turn, maintain constant altitude, and roll out on original heading.
5	Ground handling	Taxi model back and forth on runway keeping it lined up with the centerline.
6	Take-off in both directions	Smooth lift off and straight climb out.
7	Rectangular approach and landing	Perpendicular and parallel segments with good lineup on final approach to touch down.
8	S-turn on landing approach	Executing of S-turns on an intentionally high final approach to loose altitude for landing.
9	Touch and go's	Executing normal approach and landing, followed by an immediate take-off straight down the runway.
10	Reset trim	Instructor changes elevator and aileron trim, student resets
11	Dead stick landing	From a high altitude and idle throttle setting land model on runway.
12	Two consecutive loops	Perform two inside loops in succession.
13	Stall/Spin & recover	If aircraft able, at least two turn spin.